



Regupol®

TECHNICAL DATA SHEET

REGUPOL® 3912 ACOUSTIC ISOLATION STRIP

PRODUCT DESCRIPTION

Regupol® 3912 Acoustic Isolation Strips are designed to sit beneath all types of partition walls and are a very simple and effective way to reduce structure borne noise. There are a number of different Regupol® materials that can be installed as Isolating Strips, each one tailored to withstand a specific weight per linear metre, therefore we have a Regupol® solution for all partition requirements.

BENEFITS

- Standard thickness 6mm, although other thicknesses are available upon request
- Offers long term performance without collapse or “bottoming” out under high point loads
- Resistant to ageing and deformation
- Quick and easy to install - simply bond to the subfloor beneath the partition
- Minimises construction heights
- Available with various backings including self adhesive backing and Class ‘O’ foil facing
- Product manufactured using Recycled Materials and 100% recyclable

STORAGE

Regupol® 3912 Acoustic Isolation Strips must be stored indoors. At no time must the Regupol® 3912 Acoustic Isolation Strips be exposed to the elements of the weather. Regupol® 3912 Acoustic Isolation Strips must always be kept dry, otherwise moisture will build up in the material and will subsequently make bonding to the subfloor very difficult. Moisture will also

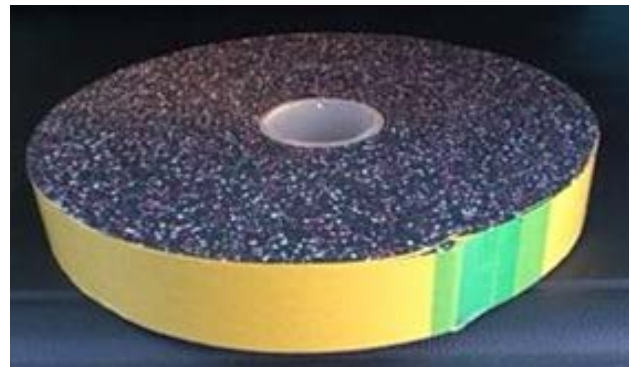

cause the material to curl and ripple at the edges once unrolled. It is recommended that packaging be removed in the area where it shall be applied.

PHYSICAL INFORMATION

Material thickness	6mm
Standard strip widths	50mm, 75mm and 100mm Non standard widths are available upon request
Roll length	15m

INSTALLATION SERVICE

In addition to supply of this product CMS Danskin Acoustics can provide a listing of competitively-priced approved installers that service anywhere in the UK. Use of this service ensures that installation is performed to the highest standards by tradesmen fully experienced in the specialist skills of fitting CMS Danskin Acoustics materials correctly. For further details contact your local office.

www.cmsdanskin.co.uk

CMSDANSKIN
ACOUSTICS

INSTALLATION EXAMPLES

Timber Stud Frame

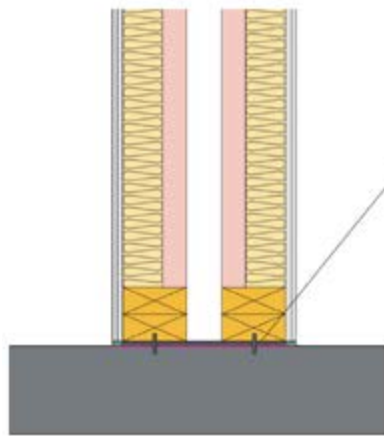

Section

Regupol® 3912 Acoustic Isolation Strip

Regupol® 3912 Acoustic Isolating Strips can be bonded to the applicable subfloor using Regupol® Regubond 100 or equal approved or alternatively mechanically fix although we strongly recommend the fixings be isolated using Regupol® HT washers

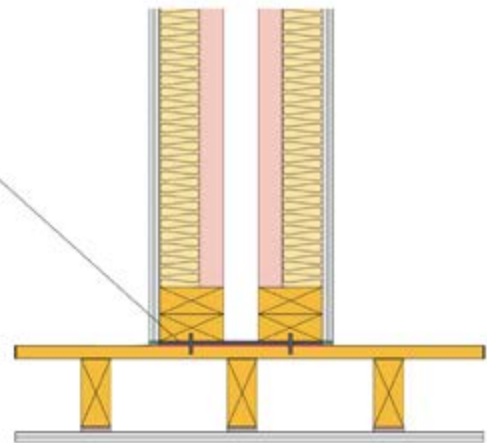

Section

Metal Frame

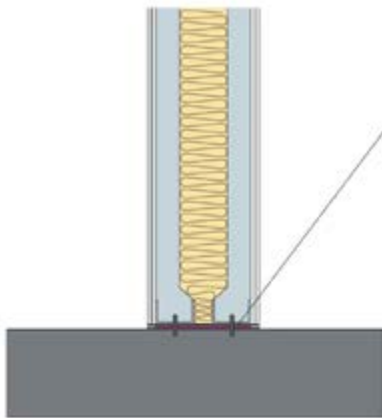

Section

Regupol® 3912 Acoustic Isolation Strip

Regupol® 3912 Acoustic Isolating Strips can be bonded to the applicable subfloor using Regupol® Regubond 100 or equal approved or alternatively mechanically fix although we strongly recommend the fixings be isolated using Regupol® HT washers

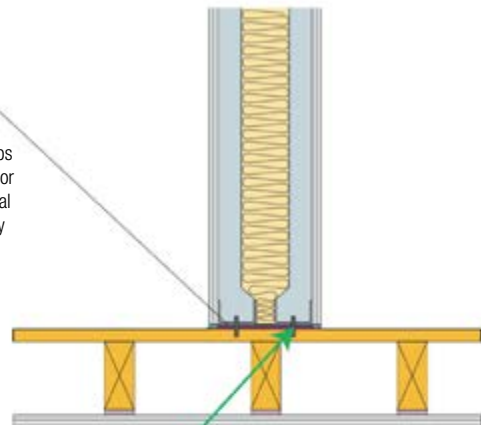

Section

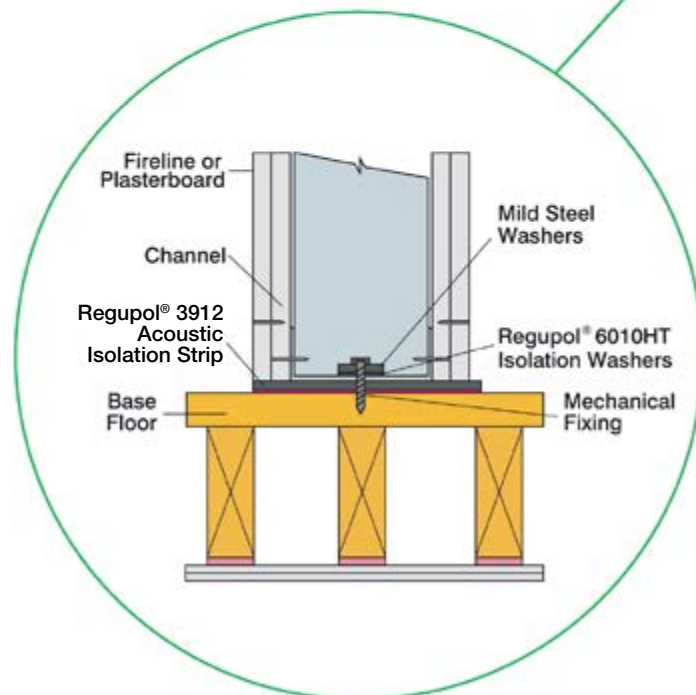

Joist Isolation

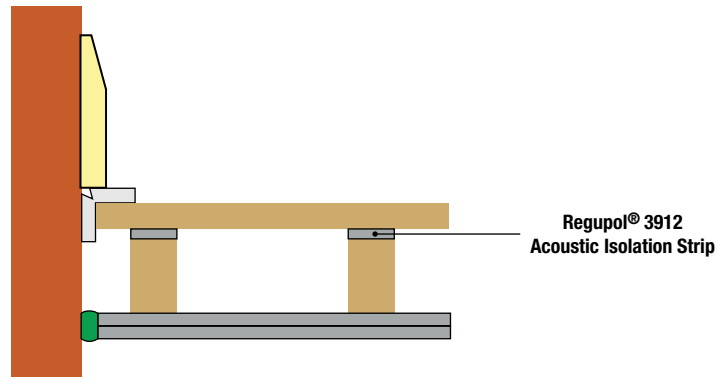

These diagrams are for illustrative purposes only and are intended to show the installation of a Regupol® Isolating Strip. For information relating to your specific applications, please contact CMS Danskin Acoustics.

N.B.

- The recognised technical rules of the industry, and the code of practice requirements of BS8203 “Installation of Resilient Floor Coverings” are to be observed
- Regupol® Acoustic Underlayments can be easily installed providing BS8203 and our installation guidelines are observed

Important Note:

- All partitions to be fixed in accordance with manufacturers guidelines. If mechanically fixing please ensure all fixings are isolated using Regupol® 6010HT washers and mild steel washers

CMS DANSKIN ACOUSTICS

Scotland Office: Tel: **01698 356000** Fax: **01698 372222**
1 Netherton Road Wishaw ML2 0EQ

Central/Southern Office: Tel: **01925 577711** Fax: **01925 577733**
Unit 2 Lyncastle Road, Appleton, Warrington, WA4 4SN

Email: info@cmsdanskin.co.uk Website: www.cmsdanskin.co.uk

IMPORTANT: Goods supplied by the company are made to approved standards from the highest quality raw materials but no warranty or guarantee is given as to their suitability for any particular purpose or application, and no liability is accepted for any loss or damage arising directly or indirectly from the use of the Company's products irrespective of any information given to us as to intended use of such products. It is therefore recommended that prospective users should test a sample of this product under their own conditions to satisfy themselves that the product is suitable for the purpose intended.

CMSDANSKIN
ACOUSTICS